

valken



WARNING:

THIS IS NOT A TOY! MISUSE MAY CAUSE SERIOUS INJURY OR DEATH. EYE, FACE, AND EAR PROTECTION DESIGNED SPECIFICALLY FOR THE SPORT OF PAINTBALL MUST BE WORN BY THE USER AND ANY PERSON WITHIN RANGE. WE RECOMMEND AT LEAST 18 YEARS OLD TO PURCHASE. PERSONS UNDER 18 MUST HAVE ADULT SUPERVISION WHEN USING THIS PRODUCT. READ THE OWNER'S MANUAL BEFORE USING.

TECHNICAL MANUAL

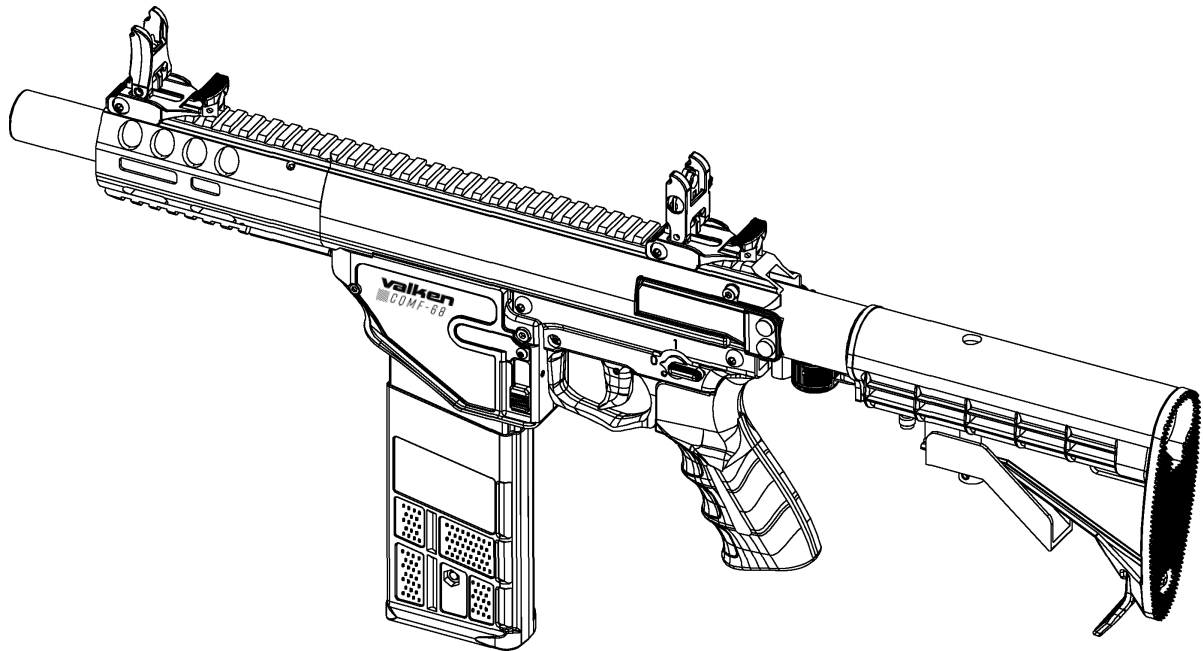

Includes:

Marker
Polymer Flip Up Sights
1 19 Round Paintball/FSR Magazine
1 Tool Kit and Barrel Plug

WARNINGS

- Do not load or fire this marker until you have completely read this manual and are familiar with its safety features, mechanical operation, and handling characteristics.
- Handle this and any marker as if it were loaded at all times.
- Keep your finger off of the trigger until ready to shoot.
- Do not look down the barrel of a paintball marker. Accidental discharge into the eyes may cause permanent injury or death.
- Keep the marker on safe until ready to shoot.
- Keep the barrel plug installed on marker when not shooting.
- Never point the marker at anything you do not intend to shoot.
- Never fire your marker at anything you do not intend to shoot because there may be balls or foreign debris lodged in the chamber, barrel, and / or marker valve.
- Do not shoot at fragile objects such as windows.
- Never fire your marker at personal property of others; the paintball can stain the paint of automobiles and houses.
- Always keep the muzzle pointed in a safe direction, even if you stumble or fall.
- Eye, face, and ear protection designed specifically to stop paintballs in the form of approved goggles, and full face mask should be worn by the user and any person within range.
- Never shoot at a person who is not protected by eye, face, and ear protection designed for paintball.
- Pressurize and load the marker only when the marker will be immediately used.
- Before storing or disassembling, be sure to point your marker in a safe direction, fire several times to be sure there are no balls lodged in the chamber and / or barrel or air left in the marker. Install barrel plug.
- Store the marker unloaded and degassed in a secured place.
- Familiarize yourself with any warnings and instructions listed on the air supply cylinder.
- Contact the air supply cylinder manufacturer with any questions.
- Do not field strip or otherwise disassemble this marker while it is pressurized with air.
- Dress appropriately when playing the game of paintball. Avoid exposing any skin when playing the game of paintball.
- Even a light layer will absorb some of the impact and protect you from the paintballs.
- Keep exposed skin away from escaping gas when installing or removing air supply cylinder or if the marker or air supply is leaking. Compressed air, CO₂, and nitrogen gasses are very cold and can cause frostbite under certain conditions.
- Use only 68 caliber paintballs, never load or fire any foreign objects.
- Avoid alcoholic beverages before and during the use of this marker. Handling markers while under the influence of drugs or alcohol is a criminal disregard for public safety.
- Avoid shooting an opponent at pointblank, 2 Meters or less.
- Familiarize yourself with instructions listed on air supply cylinder or adaptor. Contact the air supply cylinder or adaptor manufacturer with any questions.
- Always measure your marker's velocity before playing paintball, and never shoot at velocities in excess of 300 feet per second.

WARRANTY

Valken warrants that this product is found free from defects in materials and workmanship for a period of 180 days from the original date of purchase by the original owner. Unauthorized modifications, alterations, neglect or abuse of this product voids this warranty. The warranty only covers the parts and labor required to repair the product to proper working order. Valken is dedicated to providing you with the best product and excellent support for your ultimate paintball experience. Additional charges such as shipping, or parts required as a result of misuse may not be covered under this warranty policy. See www.valken.com for full warranty details.

EXCEPT WHEN MARKER IS IN USE, ALWAYS MAKE SURE THAT THE BARREL PLUG IS INSTALLED AND THE SELECTOR SWITCH IS IN SAFE MODE, WHICH DISABLES THE TRIGGER.

SAFETY

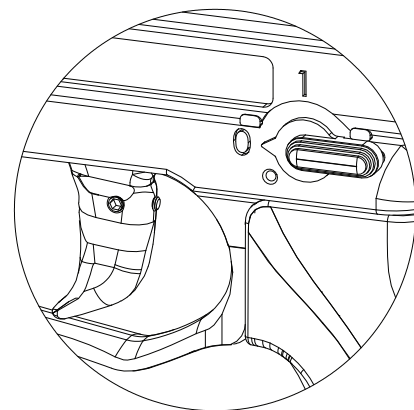
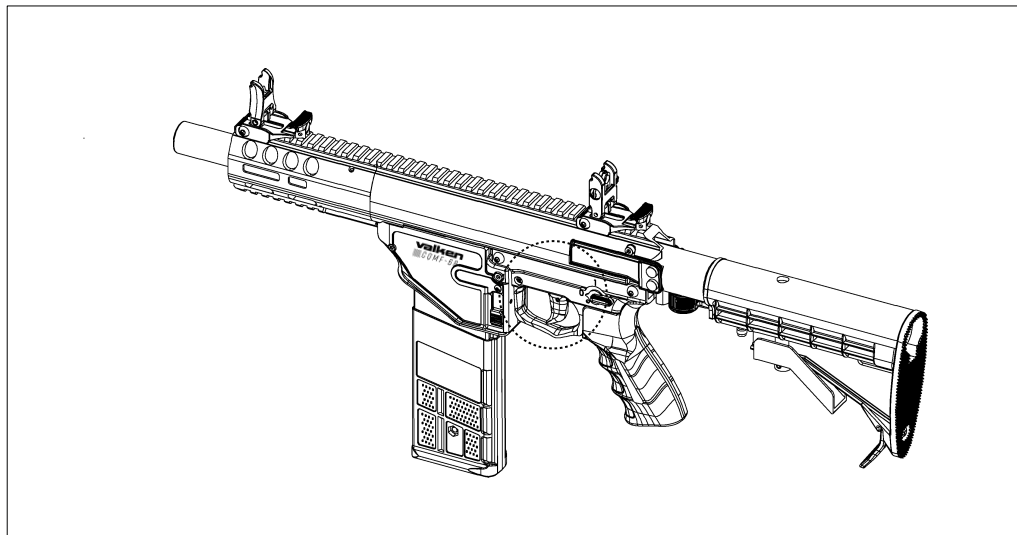

To turn ON the Safety (SAFE MODE):
To turn OFF the Safety (FIRE MODE):

Rotate Selector Switch counterclockwise until the arrow points to "0"
Rotate Selector Switch clockwise until the arrow points to "1" for semi auto;
to "∞" for full auto.

BARREL PLUG

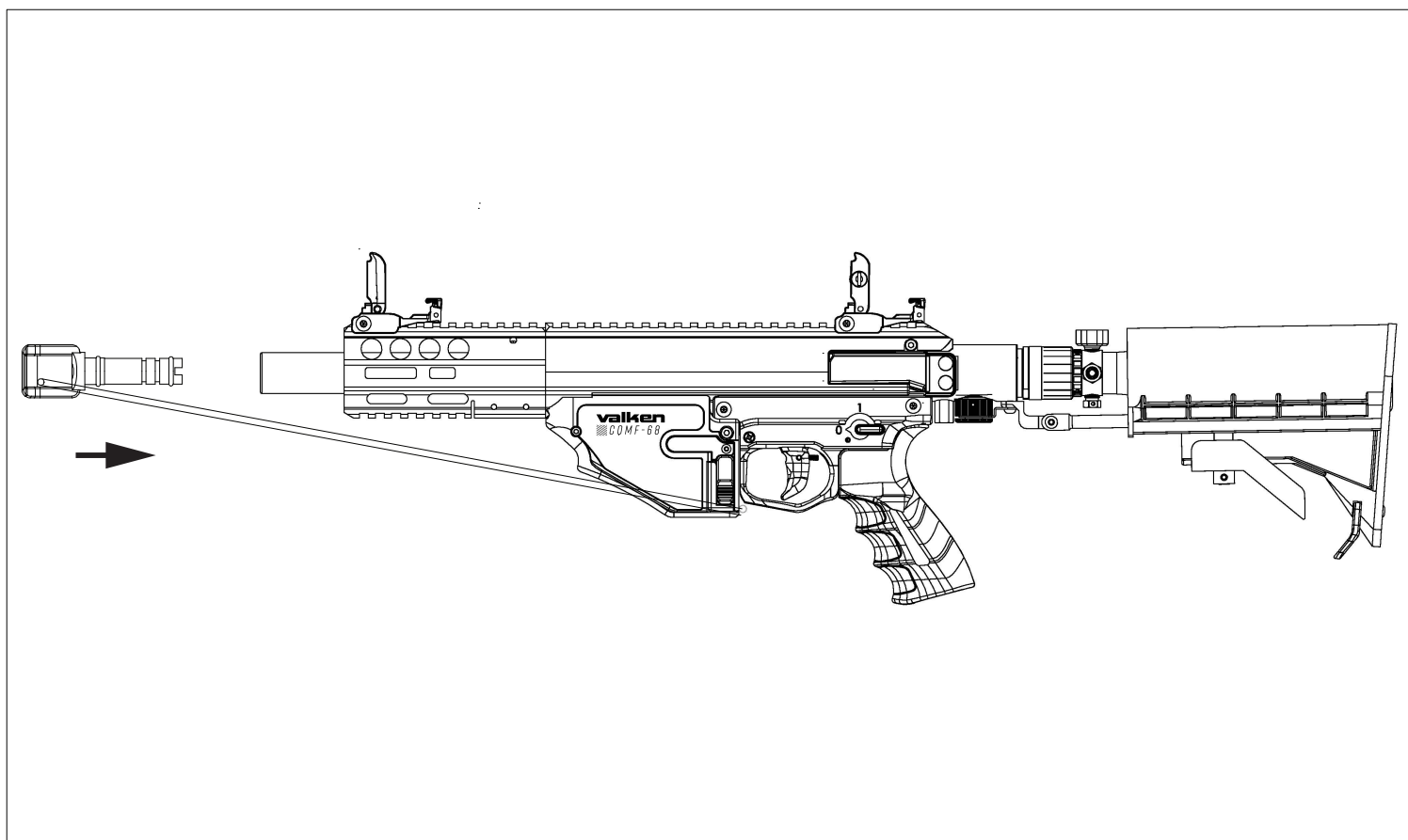

1. Insert plug into barrel and loop under the Magazine Well as shown.
2. Pinch cord length adjuster button and hold to back of Magazine Well as you pull cord through it until adjuster is snug against the back of the magazine well, then release.
3. Check to be sure there is enough cord elasticity to pull cord / adjuster off to remove barrel plug for firing.
4. After the cord length is adjusted, lock cord length by tying a knot in the cord against the back of the adjuster.

STEP 1. FILL MAGAZINE

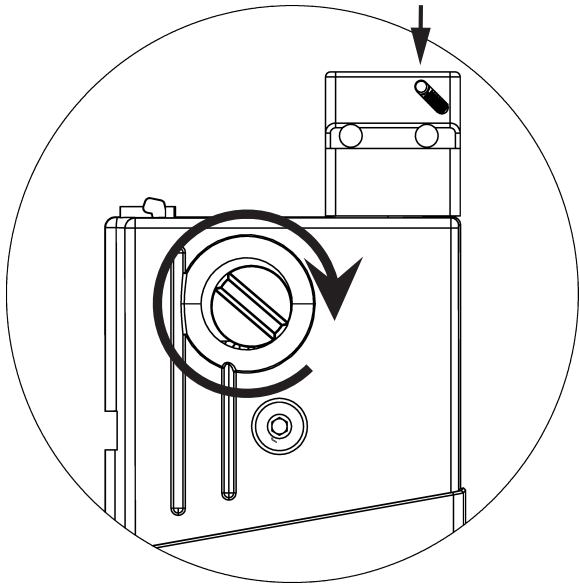

- A. Turn Magazine winder clockwise until tight. Do NOT overtighten.
- B. Hold down Ball Detent Bar and feed paintballs in one by one.
- C. Fill to capacity. Do NOT partially fill Magazine.

NOTE.

The Marker comes with a 19 rounds paintball / FSR magazine.

For use with more brittle paintballs, we recommend the use of the 20 rounds paintball magazine only. (Purchased Separately) as the stronger spring tension of the 19 rounds magazine may lead to marker malfunctions.

For easier magazine winding, use the tip of the barrel plug as a magazine winding tool.

WARNING: DO NOT Insert Magazine into your marker until it's aired up.

STEP 2. ATTACHING AIR SOURCE

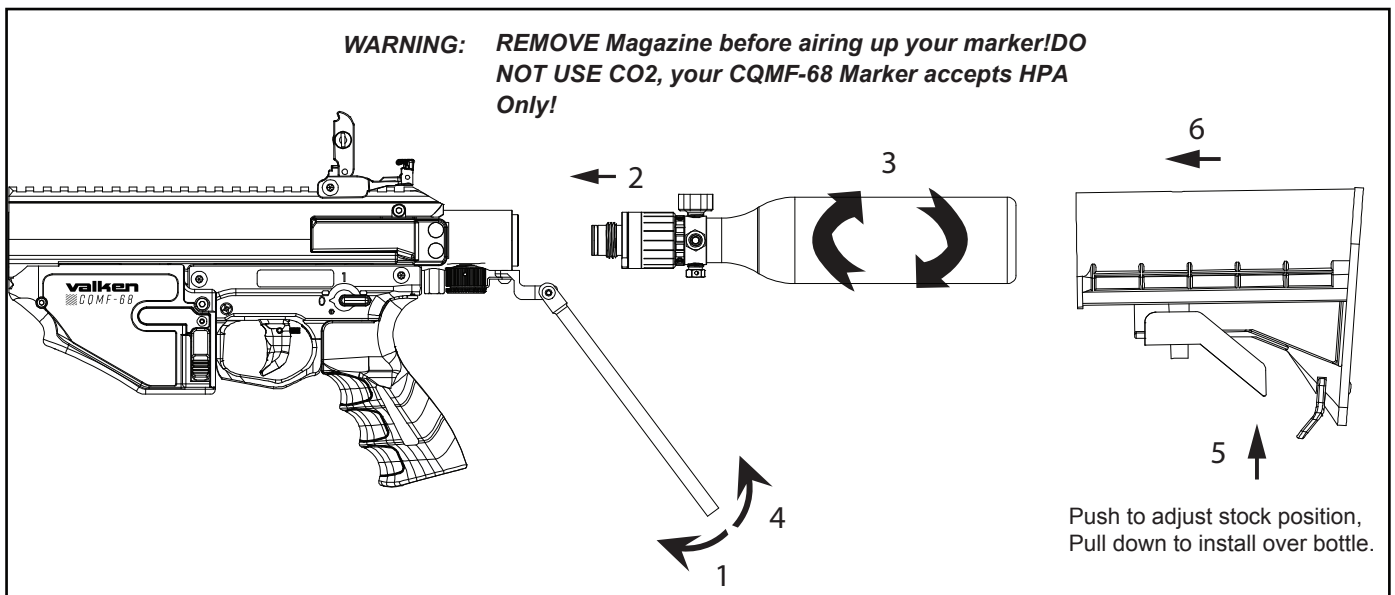

Your marker includes the Combat Air Thru Stock (C.A.T.S.) which is meant to be used in conjunction with a remote line and external air source. The marker can be changed to operate with the Hybrid Collapsible Stock (H.C.S.) or a 13 cu air system as well. These accessories must be purchased separately.

HPA BOTTLE INSTALLATION

- A. REMOVE Magazine and ensure breech is empty and barrel plug is installed (see P.3)
- B. Ensure that the HPA regulator output pressure is set between 600 and 850psi, and has adjustable bonnet positions.
- C. Lower Stock Guide Rail and insert bottle into back of the marker, turn clockwise to tighten.
- D. With the Air Bottle In place, check the position of the fill nipple and pressure gauge. If either the fill nipple or pressure gauge obstructs the guide rail, follow the Regulator Manufacturer's guide to reposition the Air Regulator.
- E. Install stock over the bottle and adjust to the desired position, fill Air Bottle to appropriate air pressure.

STEP 3. ATTACHING BARREL AND ACCESSORIES

Insert barrel into marker, turn clockwise to tighten. Your Marker comes with detachable sights, which are not factory installed. Simply place sights at the desired rail position and tighten screws. Any other accessory should be attached to the marker at this time.

STEP 4. CHECKING THE VELOCITY

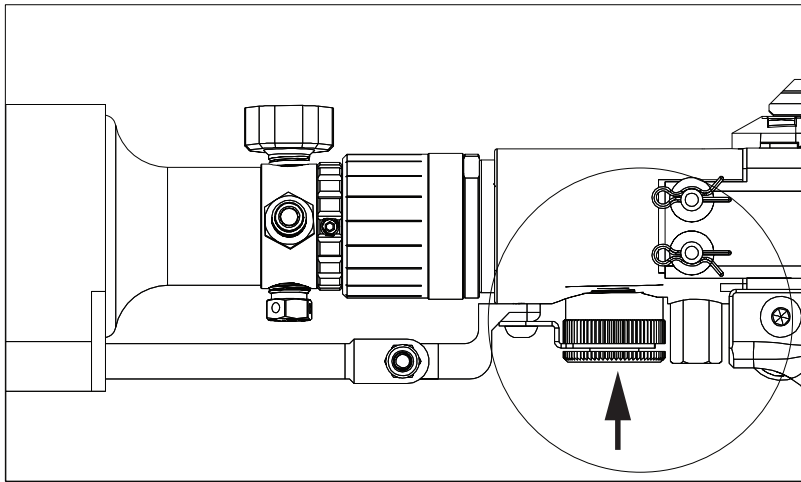

The Velocity Adjustment Set Screw is located on the underside of the HEAT CORE Regulator

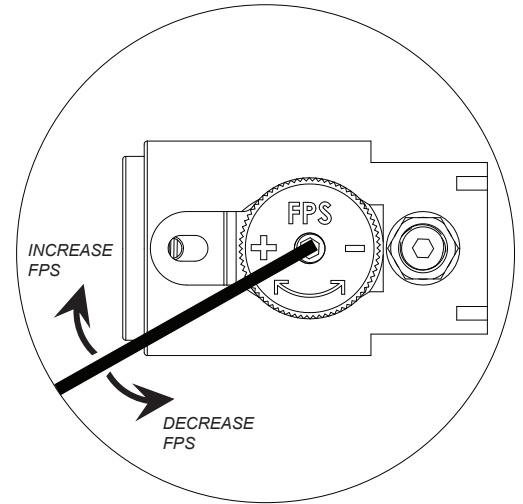

Adjust output pressure with 3mm Allen Wrench via Velocity Adjustment Set Screw

- A. Make sure you and everybody around you is wearing Paintball Approved Masks.
- B. Make sure the Marker is on safe by checking the Selector switch.
- C. Fill Pre-Installed Air Bottle with HPA (High Pressure Air) Only.
- D. Insert pre-filled Magazine, release safety, and fire several shots over chronograph to check initial muzzle velocity; the factory setting is approximately 275fps, but a + / - 15 fps variance can occur due to different playing environments.
- E. Increase velocity by turning velocity adjustment set screw clockwise, or decrease velocity by turning Adjustment Screw counterclockwise. Fire several shots to retest velocity once further adjustments are made.
- F.

NOTE: Allow Air Pressure to stabilize inside the marker after every velocity adjustment by firing multiple shots over the Chronograph. Velocity changes may require several shots before taking effect. Marker may discharge one single shot when it is first aired up. This is caused by a bolt left in its forward position from previous use. The bolt will reset itself and is not a sign of a malfunction.

WARNING: DO NOT EXCEED 300 FPS, DOING SO IS UNSAFE FOR YOURSELF AND OTHER PLAYERS AROUND YOU AND CAN CAUSE DAMAGE TO YOU MARKER.

CHANGING MAGAZINE

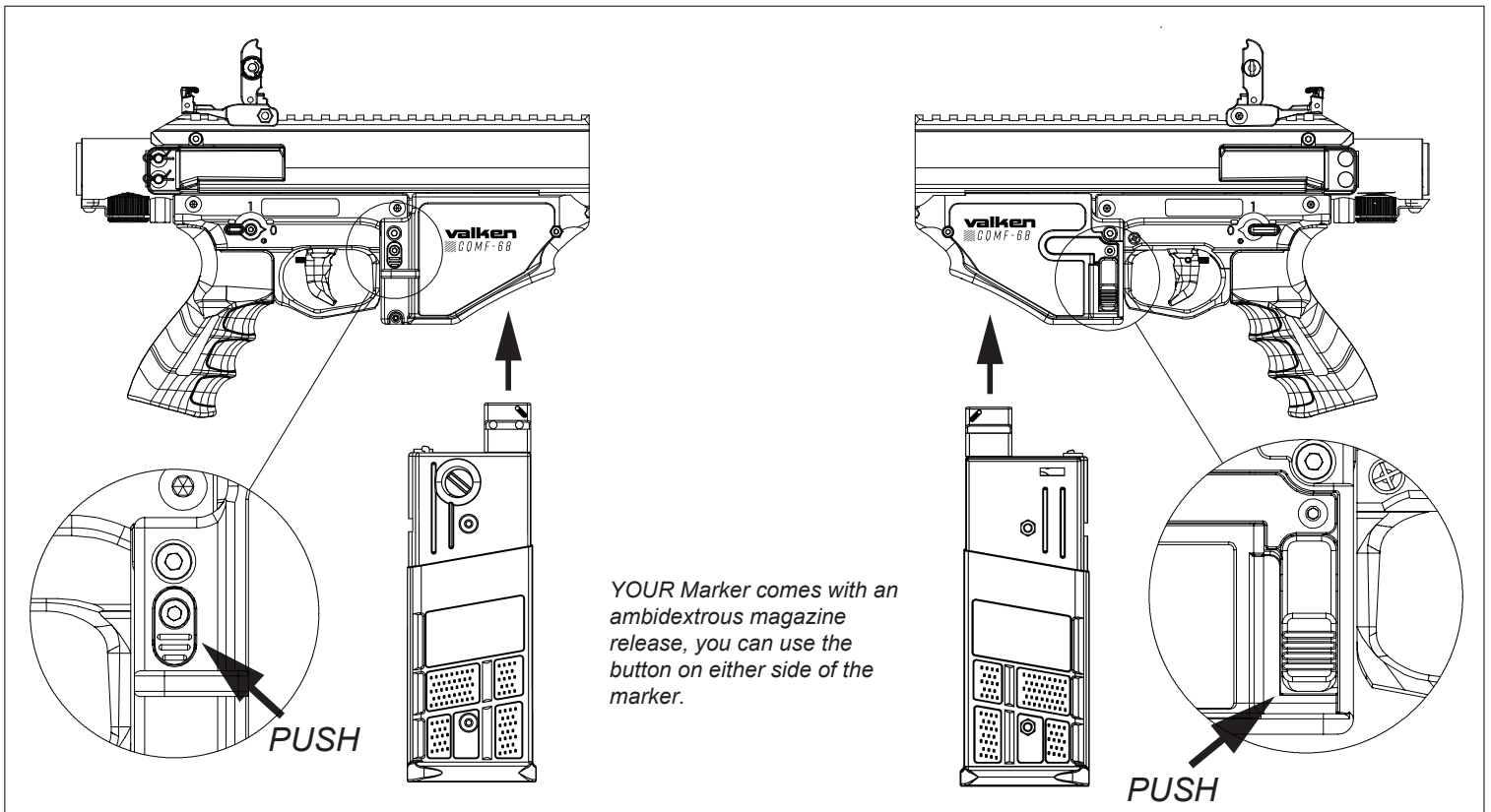

RELEASE MAGAZINE

With the barrel pointing AWAY from you, depress the Magazine Release Button.

LOAD MAGAZINE

Orient Magazine as shown and insert FIRMLY into Magazine Well until it clicks and locks into place.

TRIGGER ADJUSTMENT

Your Marker is designed to function primarily as a Semiautomatic fire, Mechanical Magazine Fed Marker. It is tuned for maximum efficiency and accuracy in this firing mode. It also has a Full Automatic fire capability that can be used periodically to enhance your experience. While the default Semiautomatic fire mode will function within the normal working perimeters of the marker, the Full Automatic firing mode has more specific perimeters that must be met for smooth operation.

- A. Muzzle Velocity must be set between 240 fps and 290fps
- B. Air tank input pressure must be between 600 and 850psi (Do NOT exceed 850PSI!)
- C. Trigger must be set properly

The Trigger may need periodic adjustment for the Full Automatic fire mode to function smoothly. Full Automatic Fire can only be achieved when the Trigger Adjuster (illustrated as "B") is set to its "sweet spot". The sweet spot location changes with the system operating pressure or muzzle velocity.

For example, if the marker is set up for use at an outdoor field at 280fps, and then lowered to 240fps for indoor use, the Full Auto mode may not function smoothly. A small adjustment may be necessary once the marker is set at the lowered velocity, and again when the velocity is raised back up for outdoor use. Note that your trigger is factory set at 275fps.

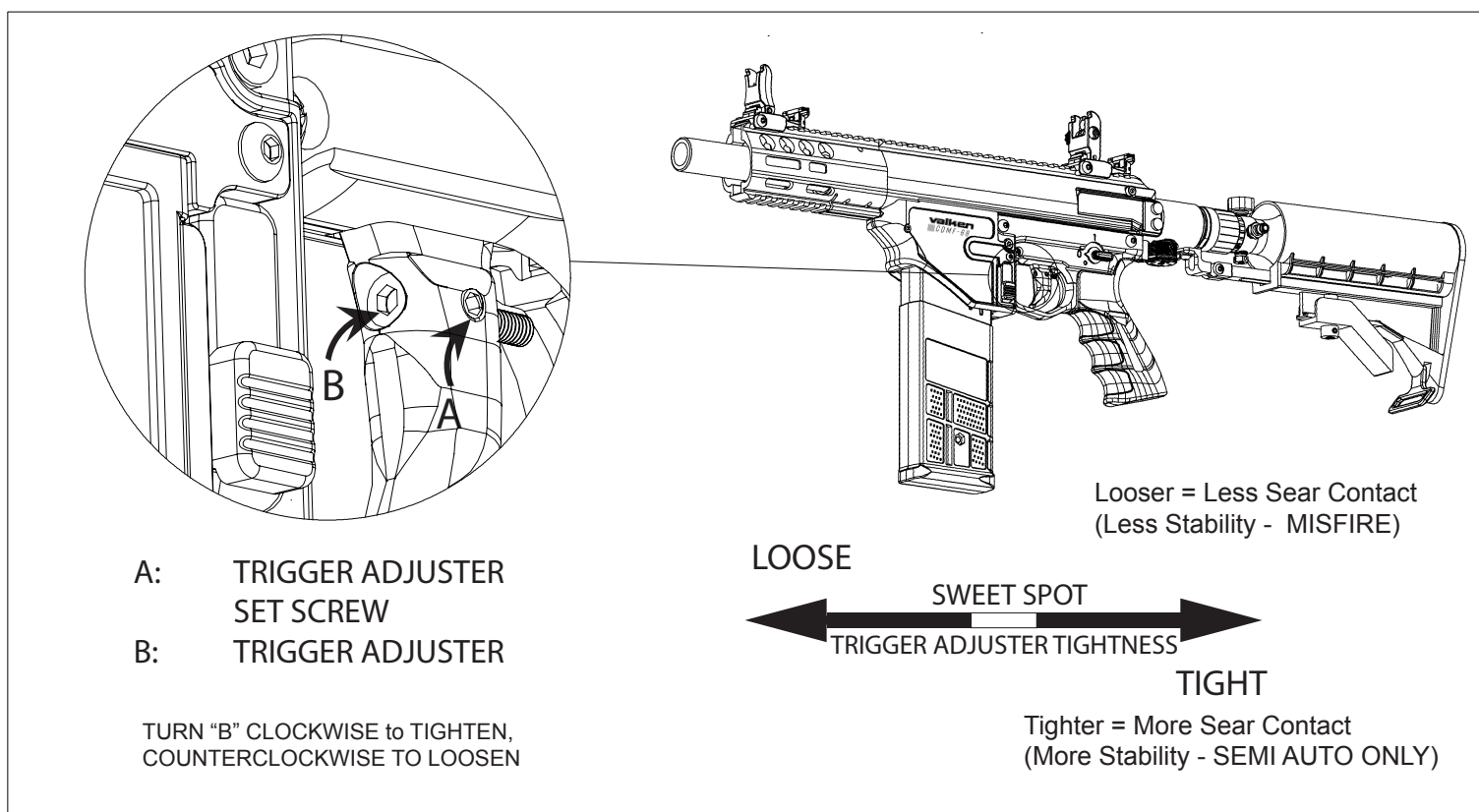

The Trigger Adjustment process should be performed immediately after the marker has been chronographed, and the desired muzzle velocity is set.

- A. Remove magazine and clear the marker of paintballs. (The entire Trigger Adjustment process is performed by dry firing only.)
- B. Ensure that there is sufficient Air Pressure inside the Air Bottle.
- C. With Selector Switch set to Full Auto Fire mode, pull the trigger and perform a 2-3 second burst.
- D. Note how the marker behaves during the burst test, if the Full Auto Burst is inconsistent, or that the marker misfires, the Trigger Adjuster will need to be tightened. If the marker does not sustain a steady burst, or that it only shoots Semiauto, the Trigger Adjuster will need to be loosened. If the marker does a steady burst, no adjustment is needed.
- E. To adjust, loosen the Trigger Adjuster Set Screw (labeled as "A" on the diagram above) by turning it counterclockwise with a 1.5mm Allen Wrench; do not completely remove.
- F. Insert a 2.5mm Allen Wrench into the Trigger Adjuster (labeled as "B" on the diagram above) and turn clockwise to tighten, and counterclockwise to loosen. Turn Trigger Adjuster only 1/8th of a turn at a time, and fire a test burst after every minute adjustment. Once you are able to achieve a smooth burst, the Trigger is set.
- G. Tighten Trigger Adjuster Set Screw "A" by turning it clockwise. Turn it until finger snug, do not overtighten.

Standardized AR Grip:

Your Pistol Grip is standard AR sized. The grip frame will accept most aftermarket pistol grips designed for the Armalite Rifle. Do note that some aftermarket grips may not have contours that matches perfectly with your grip frame. To change grip, simply remove grip locking screw with 3.0mm Allen Wrench.

WARNING: *The Selector Switch Spring and Ball Bearing can fall out when removing the grip. Ensure that you remove the grip slowly and on a suitable surface where these parts can be easily recovered.*

If the aftermarket grip you wish to install comes with its own screw, do NOT use it as the threading may be different. Use ONLY the original MILSIG grip screw.

MAINTENANCE

WARNING:

Before conducting any marker maintenance, remove magazine / loader, point marker in a safe direction, and discharge until degassed.

These Additional Tools may be required for maintenance or marker take-down:

Lubricant
Small Phillips Head Screwdriver
Small Flat Head Screwdriver
Small Pick for removing O-Rings
Tech Mat

Maintenance Intervals:

We recommend a thorough check of the marker before every use, to ensure that all parts are securely installed, and o-rings are properly lubricated for best performance.

Pre-Use Check:

1. Remove HEAT CORE from marker by removing RECEIVER / HC PINS. (refer to P. 10 "RECEIVER 2")
2. Remove Bolt from Air Chamber, check Bolt and make sure that all parts are securely fastened.
3. Check Air Chamber and make sure that all parts are securely fastened.
4. Check AC Bumper O-Ring, replace if there are any signs of wear. (refer to P. 12 "HEAT CORE")
5. Place one dab of lubricant on the surface of the AIR CHAMBER BODY (refer to P. 12 "HEAT CORE")
6. Remove any excess lubricant with a soft cloth or paper towels. DO NOT over lubricate, over lubrication can lead to marker malfunctions.
7. Place one dab of lubricant on AC Main O-Ring (refer to P. 12 "HEAT CORE").
8. Place Bolt over Air Chamber, install Bolt Spring, and re-install HEAT CORE to receiver.
9. Re-Attach HEAT CORE LOCKING PINS, your marker is now ready for use.
10. Drop 1 small drop of oil into the small air hole found in your ASA. (refer to P. 12 "HEAT CORE")
11. Check Air Bottle O-Ring, replace if there are any signs of wear.
12. Proceed to marker set up (P. 4) when ready to use.

NOTE:

When re-installing your HEAT CORE back into the receiver, you must move the Selector Switch to "FIRE", and pull the Trigger while pushing on the HEAT CORE. This will allow the HEAT CORE to move past the sear.

REPLACING O-Rings:

There are only TWO O-Rings that can cause a leak from inside the marker. They're your Main Bolt O-Ring and AC to Reg O-Ring (refer to Parts: 5 and 9 on P.12- HEAT CORE)

TO REPLACE:

- A. AC Main O-Ring (Orange O-Ring) - Remove HEAT Core from Marker, separate Bolt Assembly from Air Chamber, using a small pick, carefully pry old O-Ring out from the tip of the Air Chamber and discard. Install new o-ring with a non pointy object, slowly work the sides of the o-ring into the cut out slot of the Air Chamber. Put 1 drop of oil on the o-ring, reassemble HEAT Core.
- B. AC to Reg O-Ring- This O-Ring is single use only and will not normally leak unless the Air Chamber has worked itself loose from the HC Regulator. Twist off the Air Chamber by hand, insert new o-ring into the groove at the bottom of the air chamber, twist Air Chamber back into the HC Regulator by hand. DO NOT grip the surface of the Air Chamber with any tools as it can lead to irreparable damage to the Air Chamber.

WARNING:

DO NOT USE MARKER IF ANY PART OF THE BOLT OR THE AIR CHAMBER IS LOOSE. DO NOT USE MARKER WITHOUT AN AIR CHAMBER (AC) BOLT BUMPER. DO NOT USE MARKER WITH A WORN OUT AIR CHAMBER (AC) BOLT BUMPER.

STORAGE:

1. Remove magazine or loader and remove remaining paintballs. AVOID reusing old or deformed paintballs.
2. Discharge remaining gas in the Marker and remove the Air Source.
3. Put Marker on SAFE and install Barrel Sleeve.
4. Place Marker in a suitable storage device.

MAGAZINE MAINTENANCE:

1. Remove all paintballs and / or FIRST STRIKE projectiles from your magazine.
2. Remove Magazine Body Screws with small Phillips Screw Driver.
3. Separate the Magazine Body, remove Magazine Feed Assembly and Magazine Winder Assembly.
4. Wipe off any left over paint residue from disassembled magazine parts. If desired, all parts can be washed with mild soap and warm water. Make sure to completely dry all surfaces with paper towels or a hair dryer when finished.
5. Apply light coat of oil to the feed channel of the marker body, apply 1-2 drops of oil on the winder mechanism.
6. Re-Assemble magazine when finished, do NOT overtighten Magazine Body Screws.

BALL DETENT:

The Ball Detents are located on the sides of the barrel block, please refer to "Receiver 3" on p.11

ADDITIONAL TECHNICAL INFORMATION:

For additional technical information such as How to Videos, FAQs, Performance / Upgrade Tips, and the latest product information, please refer to our website at www.milsig.com and follow us via the following social media platforms.

SPECIFICATIONS

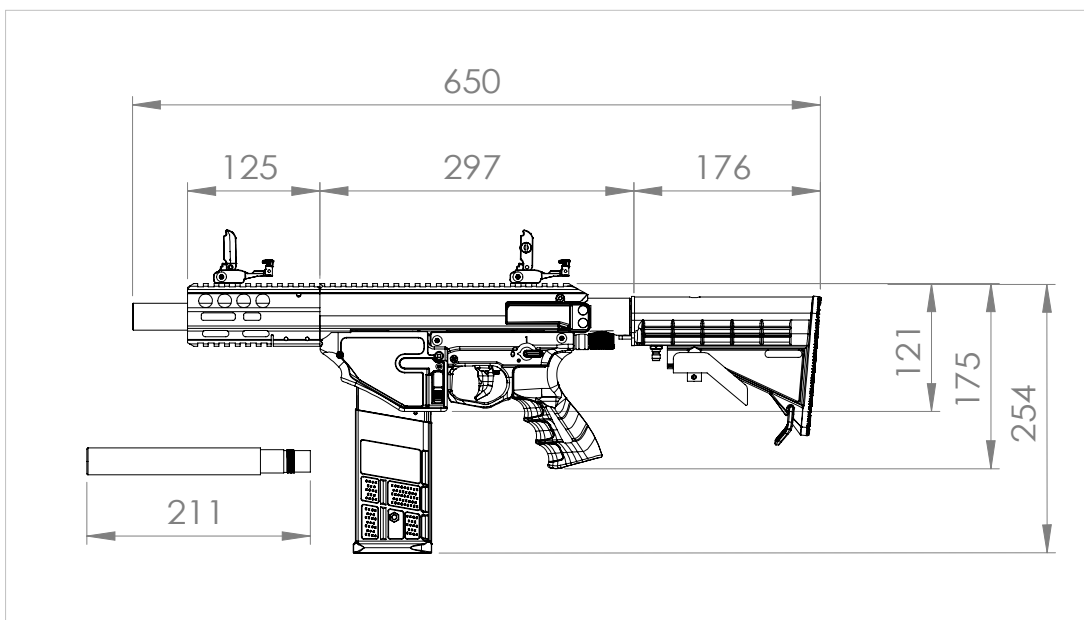
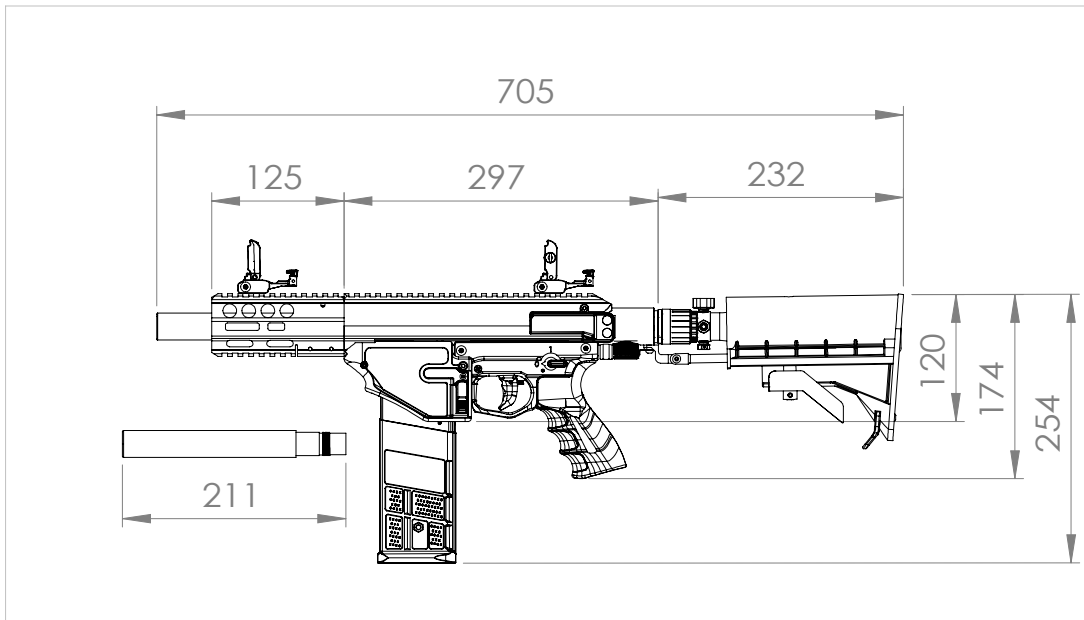

TROUBLESHOOTING

SYMPTOM: (S) / REMEDY: (R) / CAUSE (C)

1. S: Marker won't air up / Bolt Spultters when aired up.
R: A: Check marker input pressure (velocity). B: Check Air Source Air Pressure. C: Check Main Bolt O-Ring
C: The bolt cannot recock itself without sufficient air pressure, or a bad o-ring leading to bad air seal.
2. S: Marker fires a single shot on its own when it's first aired up.
R: None
C: This occurs when the bolt is left in an uncocked position after its last use. The bolt will complete a single firing cycle on its own before it recocks, this is a normal occurrence and is not a malfunction.
3. S: Bolt Spultters during use.
R: A: Check Air Source Air Pressure, refill Air Bottle if pressure is low
C: Unload magazine and check the breech for obstruction. Remove obstruction and clean breech / barrel if necessary.
C: The Air Pressure from the air source has dipped below the Minimum Operating Pressure needed for the marker's bolt to cycle. A broken paintball or FIRST STRIKE round is obstructing the bolt, disabling it from cycling.
4. S: Marker misfires / fires more than one shot with each trigger pull in Semiautomatic mode.
R: A: Remove HEAT CORE, check main bolt o-ring, replace if worn. B: Remove grip frame, check Sear Spring, and Sear. Replace one or both if necessary.
C: A worn o-ring may cause the bolt to not seal properly, thus causing it to not cycle properly. A weakened or worn sear spring or worn sear may cause the sear to not catch the bolt as it cycles, allowing the bolt to fire again before it is locked back.
5. S: Marker fires Single Shots only in Full Automatic Mode.
R: A: Check marker's muzzle velocity to make sure that it is within the operating range of the Full Automatic function, adjust velocity if necessary. B: Follow "Trigger Adjustment" instructions on (P. 7) to make sure the trigger is properly adjusted.
C: Velocity is set outside of the operating range of the Full Automatic function, or an improperly adjusted trigger.
6. S: Marker misfires / doesn't cycle properly in Full Automatic Mode.
R: A: Check marker's muzzle velocity to make sure that it is within the operating range of the Full Automatic function, adjust velocity if necessary. B: Follow "Trigger Adjustment" instructions on (P. 7) to make sure the trigger is properly adjusted.
C: Velocity is set outside of the operating range of the Full Automatic function, or an improperly adjusted trigger.
7. S: Small Air Leak (hiss) from inside of the marker.
R: A: Remove HEAT CORE From Marker. B: Check Bolt and Air Chamber for structure integrity, if any part of the Bolt and / or Air Chamber is loose, rebuild as necessary. C: Check all HEAT CORE O-Rings, replace if necessary.
C: Loose Bolt or Air Chamber causing the HEAT CORE to not seal properly. Worn O-Ring(s) causing a bad seal.
8. S: Small Air Leak (hiss) from outside of the marker.
R: A: Listen for the leak and identify source. If leak is coming from the back of the marker, it may be the air source. If leak is coming from the underside of the marker, it may be the air source or the PRV (Pressure Relief Valve). B: If leak is from air source, replace o-ring. If leak is from PRV, check and adjust marker velocity as needed. If PRV continues to leak air when marker is at a safe operating pressure, it may need to be rebuilt or replaced.
C: Bad o-ring on Air Source (Air Bottle) causing a leak around the ASA. Muzzle velocity of the marker set too high and PRV is activated. A worn or stuck PRV internal air plug causing the PRV to bleed air inadvertently.
9. S: Air Bottle cannot be screwed into the marker all the way / Fill Nipple / Air Bottle Pressure Gauge obstructs the stock rail.
R: A: Use only an Air Bottle with an adjustable position bonnet. B: Follow the Air Bottle (Regulator) Manufacturer's instruction on Bonnet position Adjustment.
C: This is self explanatory.
10. S: Body Screws too tight to remove / Sparks occur when twisting off Body Screws.
R: A: Use professional tools or purchase the "PROFESSIONAL TOOL SET" for advanced marker servicing.
C: The marker's body screws are all tightened with precision pneumatic tools at a preset tension. The tension is set high to ensure that the receiver does not come loose under the tremendous stress of the HEAT CORE's cycling. The included mini tool set is designed for only basic maintenance and may not be sufficient to completely take down the marker. Sparks may occur when loosening the body screws due to metal on metal friction and is no cause for alarm.
11. S: Can't insert HEAT CORE back into marker once taken out.
R: A: Move Selector Switch to Semi. B: Pull trigger to lower the sear and remove blockage of the HEAT CORE.
C: This is self explanatory.
12. S: Trouble removing Barrel from marker / Barrel Back gets stuck to the marker but barrel threads out.
R: A: Always use Barrel O-Ring on all threaded points of barrels and / or barrel backs.
C: Overtightening of barrel into barrel block, worn or missing barrel o-ring causing too much friction between barrel and mounting surface.

RECEIVER 3

Shroud Roll Pins-3x16

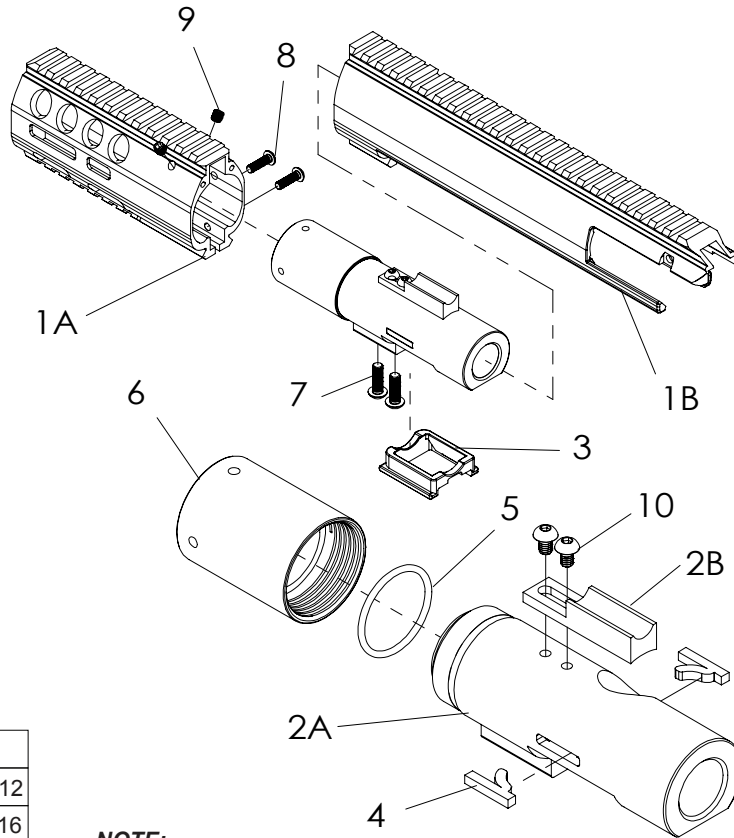

1A	Foregrip / Shroud		
1B	Receiver	6	Barrel Nut
2A	Barrel Block	7	BB/BN Screws-M4x12
3	B.B. Spacer	8	BB/BN Screws-M4x16
4	Ball Detents	9	B.N.Screws M5x6
5	B.B. O-Ring	10	BB/BN Screws-M4x6

NOTE:

[Part #7]

Bottom barrel nut screws (set of 2) and barrel block screws (set of 2) are identical.

RECEIVER 4

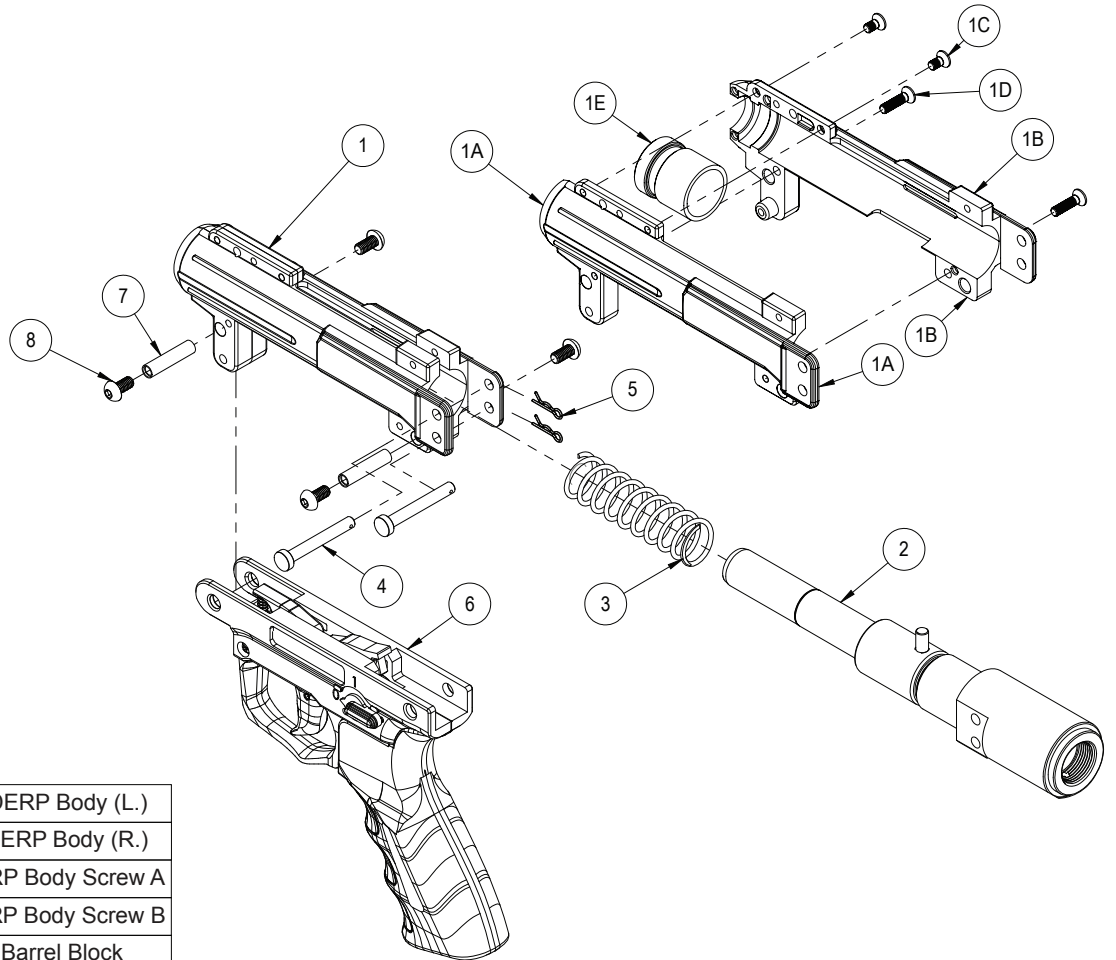

1	D.E.R.P.		
2	HEAT CORE		
3	Bolt Spring		
4	H.C. Pins	1A	DERP Body (L.)
5	H.C. Cotter Pins	1B	DERP Body (R.)
6	Grip	1C	DERP Body Screw A
7	Grip Pin	1D	DERP Body Screw B
8	Grip Screw	1E	Barrel Block

HEATCORE

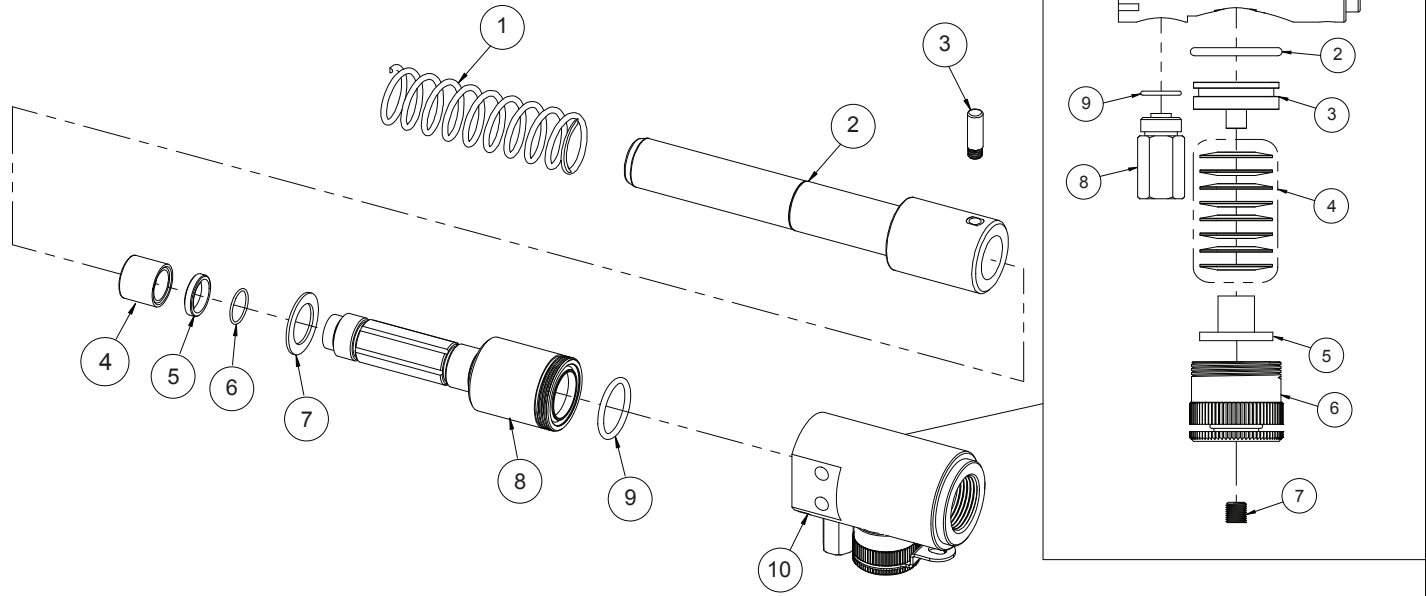

1	Bolt Spring	6	AC Cap O-Ring
2	Bolt	7	Bolt to AC Bumper
3	Bolt Stem Guide	8	Air Chamber
4	AC Cap	9	AC to Reg O-Ring
5	AC Main O-Ring	10	Regulator

1	Regulator Body	6	Reg. Cover
2	Reg. O-Ring	7	Velo. Adj. Screw
3	Reg. Piston Head	8	P. R. V.
4	Reg. Shim Stack	9	P. R. V. O-Ring
5	Reg. Piston Base		

GRIP

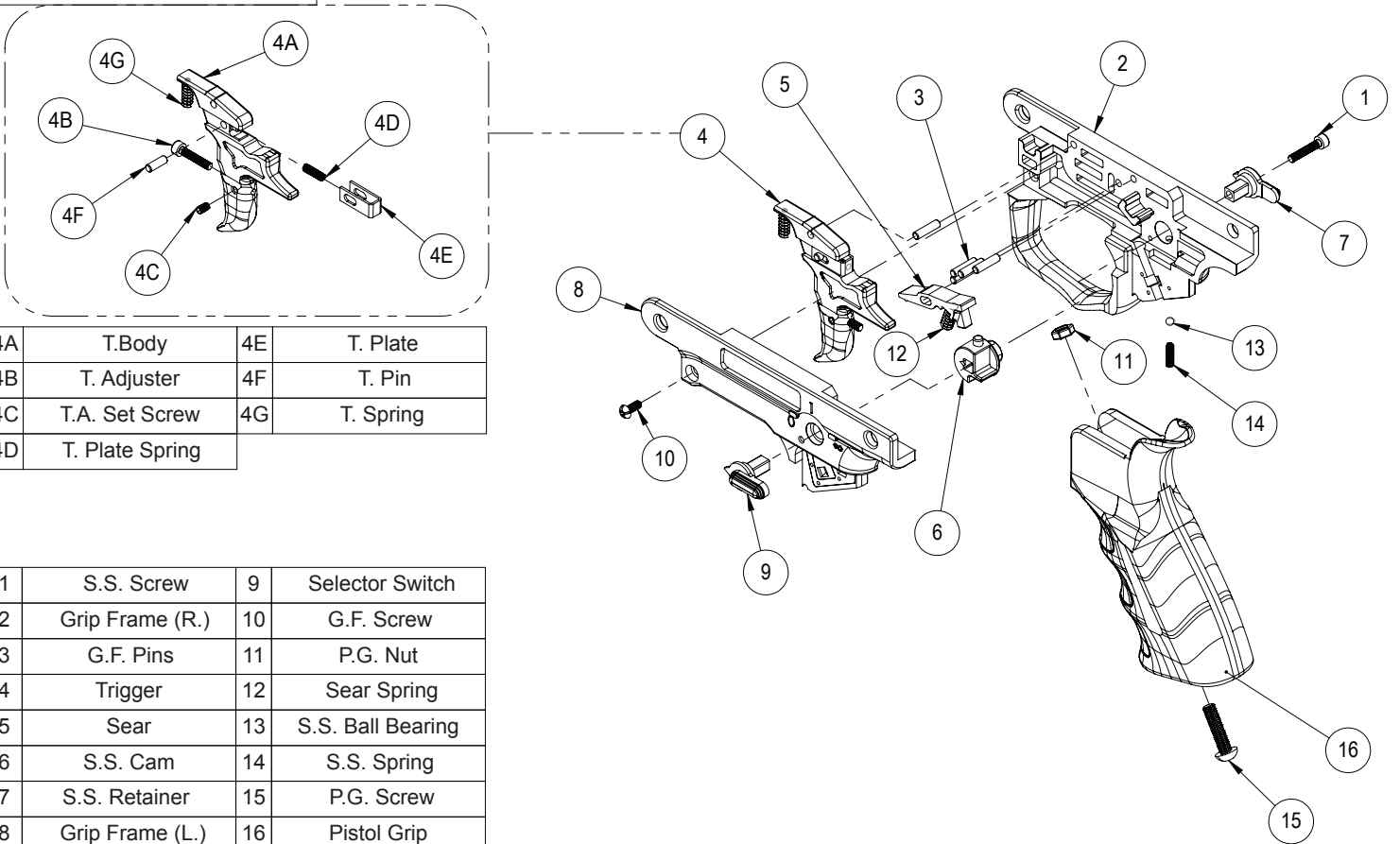

4A	T.Body	4E	T. Plate
4B	T. Adjuster	4F	T. Pin
4C	T.A. Set Screw	4G	T. Spring
4D	T. Plate Spring		

1	S.S. Screw	9	Selector Switch
2	Grip Frame (R.)	10	G.F. Screw
3	G.F. Pins	11	P.G. Nut
4	Trigger	12	Sear Spring
5	Sear	13	S.S. Ball Bearing
6	S.S. Cam	14	S.S. Spring
7	S.S. Retainer	15	P.G. Screw
8	Grip Frame (L.)	16	Pistol Grip

MAGAZINE 1

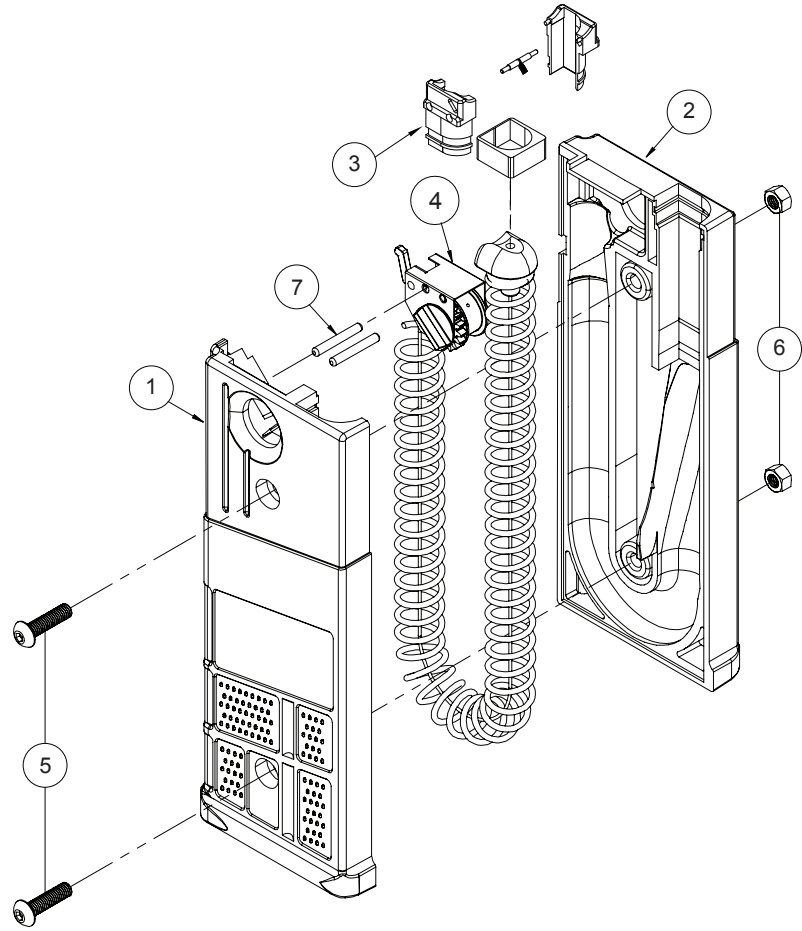

1	Magazine Body - L
2	Magazine Body - R
3	Magazine Head
4	Magazine Winder
5	Mag Screws-M5 x 20
6	Mag Nuts-M5 Hex
7	Winder Pins-3x21.8

Remote CAR Stock

